

BOTECH

ELECTRIC STACKER **PWS 10S**

Make
Your Job
Easier



BOTECH

PWS10/15S

ELECTRIC STACKER

MODEL		PWS10S	PWS15S
CHARACTERISTICS			
1.1	Drive unit	Electric	Electric
1.2	Operator type	Walkie	Walkie
1.3	Capacity	1000	1500
1.4	Load center distance	600	600
1.5	Wheel base	1245	1245
WEIGHT			
2.1	Service weight(with battery)	450/500/520/550	470/520/540/570
2.2	Service weight(without battery)	500/550/570/600	520/570/600/620
WHEEL			
3.1	Tyre type driving wheels/loading wheels	PU	PU
3.2	Size of loading wheels	φ78	φ78
3.3	Size of driving wheel	φ210	φ210
3.3	Size of balance wheel	φ180	φ180
3.4	Wheel quantity	4	4
SPECIFICATIONS			
4.1	Lift height	1600/2500/3000/3300	1600/2500/3000/3300
4.2	Mast lower height	2065/1785/2035/2185	2065/1785/2035/2185
4.3	Mast extend height	2065/3000/3500/3800	2065/3000/3500/3800
4.5	Overall length	1770	1770
4.7	Overall width	800	800
4.8	Fork dimensions	54x160x1125	54x160x1125
4.9	Width across forks	560/680	560/680
4.1	Lowered height of fork	90	90
4.11	Clearance	30	30
4.12	Aisle width for pallets (1000 x 1200mm)	2256	2256
4.13	Aisle width for pallets (800 x 1200mm)	2184	2184
4.14	Min turning radius	1390	1390
PERFORMANCE			
5.1	Travelling speed, laden/unladen	2.5/3.0	2.5/3.0
5.2	Lifting speed, laden/unladen	100/112	100/112
5.3	Lowering speed, laden/unladen	92/85	92/85
5.4	Max. gradeability, laden/unladen	5/7	3/7
5.5	Service brake type	Electronic	Electronic
ELECTRIC ENGINE			
6.1	Driving motor	0.65	0.65
6.2	Lifting motor	2.2	2.2
6.3	Battery voltage/capacity	12/85X2	12/85X2
6.4	Battery size	(260x172x214)x2	(260x172x214)x2
6.5	Controller	1212P-2501 (CURTIS)	1212P-2501 (CURTIS)

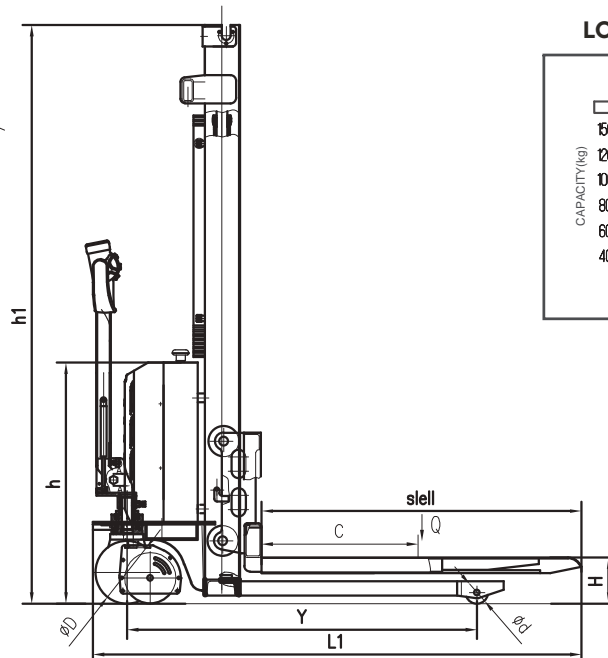
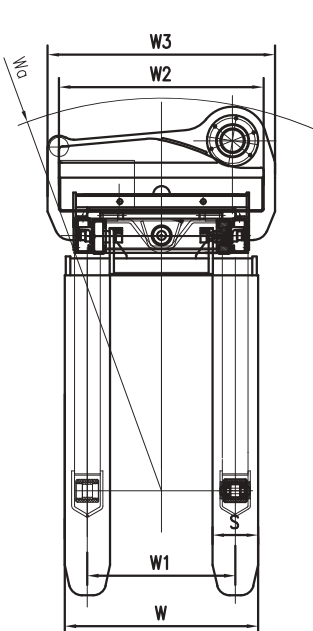

LOAD CHART

